

# PRESSURE CONTROLS

## Pressure Adjustment Options

### “A” — 1/4-in. Hex Allen Head

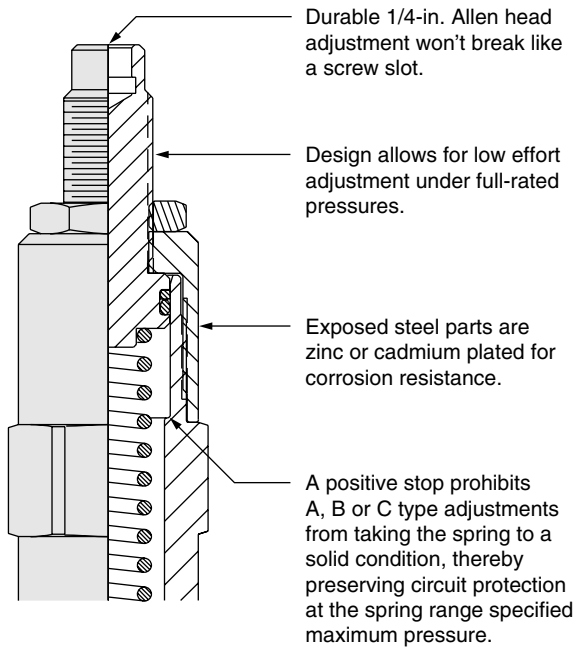

### “B” — 1 1/2-in. Diameter Aluminum Knob

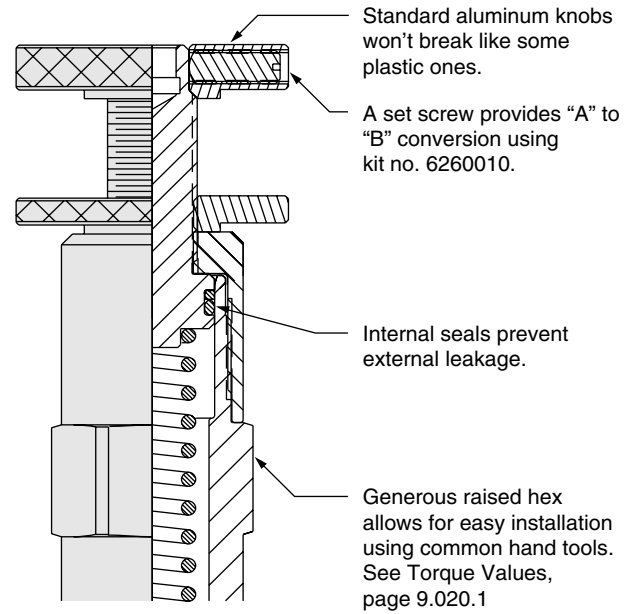

### “F” — Factory Preset, Non-Adjustable

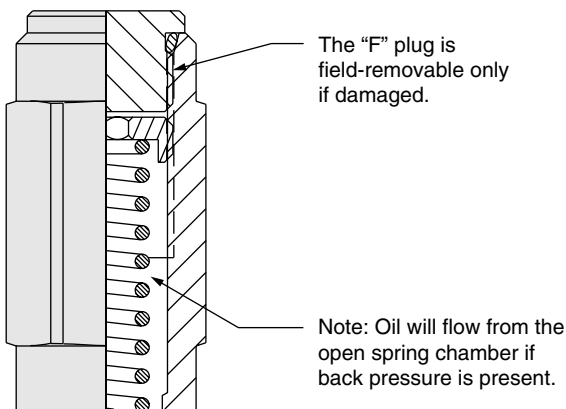

### “H” — Factory Preset, Adjustable

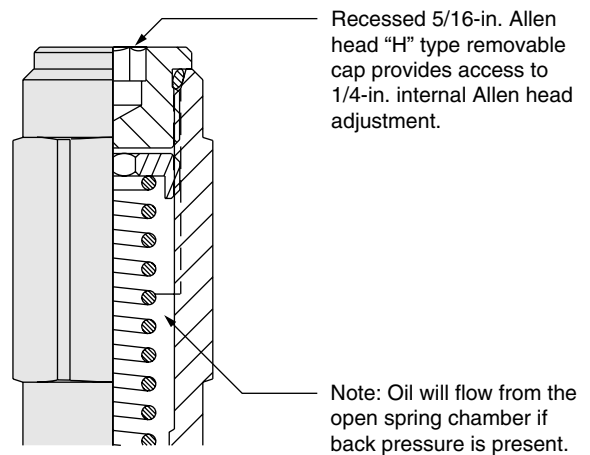

## Pressure Adjustment Options (cont'd)

### “C” — 1/4-in. Hex with Cover Cap

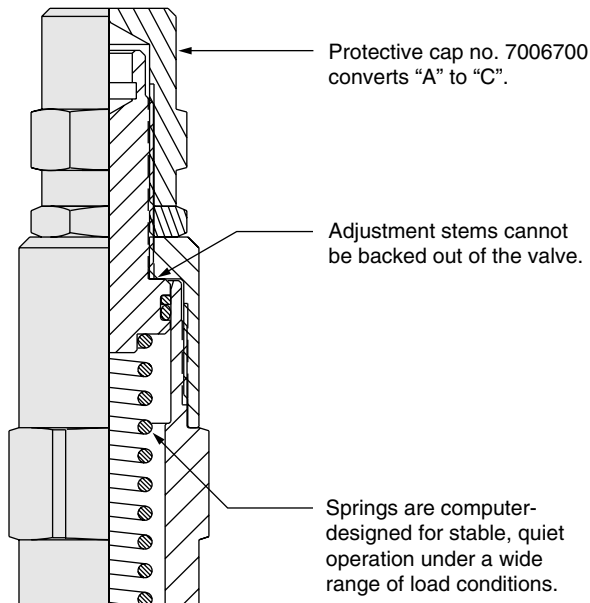

### “L” — Option “C” with Lockwire Holes

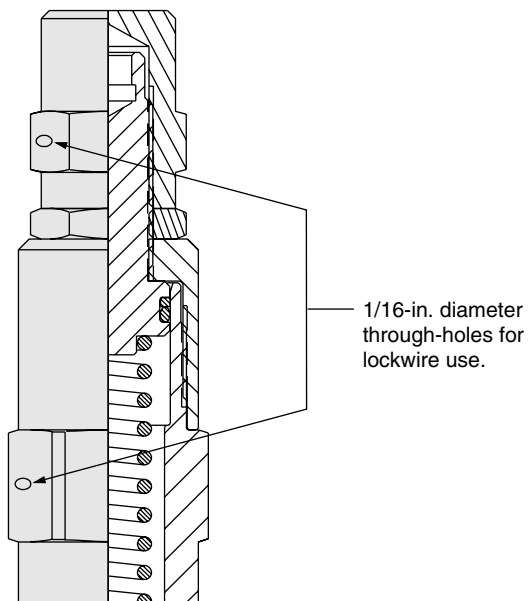

### Adjusting Without a Gauge

Percent of Spring Pressure Range Achieved at 1 Revolution:

Valve Size	Adj. Type A, B, C, L
-08	12.5%
-10	10%
-12	10%